



ZHEJIANG HANGCHA IMP. & EXP. CO., LTD.

Factory site: 666 Xiangfu Road,
Hangzhou, Zhejiang, China (311305)

Tel: +86-571-88926735 88926755
Fax: +86-571-88926789 88132890

sales@hcforklift.com
www.hcforklift.com



Follow us on
Facebook



Follow us on
YouTube



Follow us on
WeChat



Download "Hangcha
Forklift" App



ISO14001
ISO14001:2015



ISO9001
ISO9001:2015



HANGCHA trucks conform
to the European Safety
Requirements.

2022 VERSION 1/COPYRIGHT 2022/11

HANGCHA GROUP CO., LTD. reserves the right to make any changes without notice concerning colors, equipment, or specifications detailed in this brochure, or to discontinue individual models. The colors of trucks, delivered may differ slightly from those in brochures.



XE Series Electric Forklift Truck With Lithium Power

with capacities of 3,000 to 3,800kg

The World of Hangcha



XE Series Electric Forklift Truck With Lithium Power

XE series lithium battery forklifts are high quality products developed by Hangcha on the basis of the advantages of "lithium battery special structure" and "permanent magnet synchronous technology". It has two models, one is standard model and the other is heavy-duty model. Following the family design of electric forklifts, they are provided with some key parts compatible with internal combustion forklifts, and optimized mainly on the overall performance, ergonomics, reliability, maintenance, outdoor operation ability and load capacity in a bid to meet customers' use scenarios of internal combustion forklifts. The heavy-duty model is capable of meeting the application demand of users in heavy-duty working conditions.



Stylish exterior

- / Following the family exterior design of XH and XC lithium battery forklifts;
- / Boasting smooth and powerful contour lines, and simple and elegant vehicle body, and presenting both fashion and steadiness as a whole.

Comfortable experience

- / With the advantages of lithium battery forklifts, this ergonomically designed forklift enables a wide view and a large operation space.
- / The color-screen instruments are designed to have clear and intuitive graphic interfaces.
- / The optional electronic handbrake allows more comfortable driving experience.

Flexible scenarios

- / Smooth travel: ground clearance increased, to adapt to outdoor rough roads;
- / Flexible turning: turning radius reduced, to allow flexible shuttling in indoor environments such as cold store (optional);
- / No fear of cold: the battery equipped with standard electric heating module, to ensure normal operation in cold weather;
- / No fear of wind and rain: IPX4 for the whole forklift, to easily achieve water resistance of rainstorm level.

Energy-saving and efficient

- / An efficient high-torque motor together with a high speed ratio gearbox significantly improves the travel speed, gradeability and lifting speed;
- / The air-cooled fan built in the travel and lifting motors allow better heat dissipation and more thorough performance realization;
- / Oil pump reducers are introduced in the oil pump devices for the first time, enabling the lifting motor to work in a more efficient and more energy-saving manner;
- / The 80V double permanent magnet synchronous motor system allows higher power density, and through deep matching of the gearbox, motors and electronic controls, reduces the energy consumption by 15% to 20% than that of the traditional asynchronous motor models in the same working conditions.



Double permanent magnet synchronous motor system

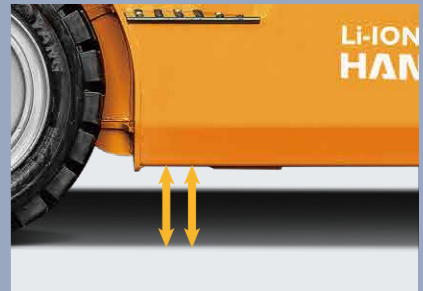

Ground clearance increased



Ergonomically designed forklift enables a wide view



Turning radius reduced

Reliable and durable

- / The enhanced drive axle and gearbox with the mast, steering axles with tapered roller bearing (for the heavy-duty model) and big tires for internal combustion forklifts can meet the demand of application in heavy-duty working conditions;
- / Low center of gravity and high load margin are designed for more stable working;
- / Verified in accordance with double standards of electric forklifts and internal combustion forklifts, with the enhanced test strength higher than that for the internal combustion standard, this forklift is reliable and durable.

Optional battery list

Capacity(Ah) Hangcha	3.0/3.5/3.8t 80V	3.0/3.5/3.8t H1 80V
230	●	/
304	○	/
460	○	●
560	/	○
608	/	○

Capacity(Ah) PengCheng	3.0/3.5/3.8t 80V	3.0/3.5/3.8t H1 80V
202	○	/
271	○	/
404	○	○
542	/	○

Note: ● Standard battery capacity; ○ Optional battery capacity;

Configuration

NO.	Configuration	Standard configuration	Optional
1	Color	Yellow-black	Other customized color
2	Particular market	/	CE Standard
3	Cold storage environment	/	-18°C -30°C
4	Mast	Standard duplex mast	Configuration Table of the Mast
5	Fork and attachment	Standard fork Fork arm carrier Load backrest	Non-standard series fork Various attachments
6	Tires	Pneumatic tire (single)	Pneumatic tire (dual) Solid tire (single) Solid tire (dual)
7	Multiway valve	Double multi-way valve	Triple valve Quadruple valve Quintuple valve
8	Tiller	Lifting and tilting joystick	Thumb switch
9	Battery	Standard lithium battery	Large-capacity lithium battery Quick-change lithium battery
10	Light	LED head lamp Turn signal lamp LED rear combination lamp	Common alarm lamp Acoustic and optical alarm lamp LED rear lamp Blue light Straight projection lamp
11	Horn	Electric horn Reverse buzzer	Right rear armrest with horn button
12	Smart module	/	Jiachen smart module Safety management module
13	Safety configuration	Emergency power-off switch Fuse box Descending buffering	Reversing radar OPS sensing system Fire extinguisher Ascending buffering
14	Parking brake	Mechanical handbrake	Electronic handbrake
15	Instrument rack space	Smart color-screen instrument (speed mode selection) Combination switch	Cigarette lighter USB port Electronic code lock (start by swiping a card)
16	Driving space	Standard overhead guard Central rear view mirror	Front windshield PVC ceiling Cab Electric fan Left and right rear view mirrors
17	Chair	Standard seat	Fully-suspended seat Semi-suspended seat
18	Other standard configuration	Drive and lifting controllers Driving and lifting motors Oil pump reducer Silent gear pump DC-DC converter Pedal pad Traction pin Integral stamped side panel and hood	

XE Series Electric Forklift Truck With Lithium Power (3-3.8)t Mast Specification

Type	Model		Lifting height	Lowered overall height		Overall height				Free lift height				Tilt range	Capacity (Mast vertical to ground)					
						Without backrest		With backrest		Without backrest		With backrest			Load Capacity at 500mm			Load Capacity at 500mm		
						3t	3.5/3.8t	3t	3.5/3.8t	3t	3.5/3.8t	3t	3.5/3.8t		FWD/RWD	Single Tire			Double tire	
Duplex wide view mast	3t	3.5/3.8t	mm	mm	mm	mm	mm	mm	mm	mm	mm	mm	mm	(°)	kg	kg	kg	kg	kg	kg
	A2A30M200	A2A35M200	2000	1554	1669	2767	2842	3145	3145	165	170	165	170	6/6	3000	3500	3800	3000	3500	3800
	A2A30M250	A2A35M250	2500	1804	1919	3267	3342	3645	3645	165	170	165	170	6/12	3000	3500	3800	3000	3500	3800
	A2A30M270	A2A35M270	2700	1904	2019	3467	3542	3845	3845	165	170	165	170	6/12	3000	3500	3800	3000	3500	3800
	A2A30M300	A2A35M300	3000	2054	2169	3767	3842	4145	4145	165	170	165	170	6/12	3000	3500	3800	3000	3500	3800
	A2A30M330	A2A35M330	3300	2204	2319	4067	4142	4445	4445	165	170	165	170	6/12	3000	3500	3800	3000	3500	3800
	A2A30M360	A2A35M360	3600	2404	2469	4367	4442	4745	4745	165	170	165	170	6/12	3000	3500	3800	3000	3500	3800
	A2A30M400	A2A35M400	4000	2654	2769	4767	4842	5145	5145	165	170	165	170	6/12	3000	3500	3800	3000	3500	3800
	A2A30M430	A2A35M430	4300	2804	2919	5067	5142	5445	5445	165	170	165	170	6/6	3000	3400	3700	3000	3500	3800
	A2A30M450	A2A35M450	4500	2904	3019	5267	5342	5645	5645	165	170	165	170	6/6	3000	3300	3600	3000	3400	3700
	A2A30M480	A2A35M480	4800	3054	3169	5567	5642	5945	5945	165	170	165	170	6/6	2950	3200	3500	3000	3300	3600
	A2A30M500	A2A35M500	5000	3154	3269	5767	5842	6145	6145	165	170	165	170	6/6	2850	3100	3400	2900	3200	3500
	A2A30M550	A2A35M550	5500	3404	3519	6267	6342	6645	6645	165	170	165	170	3/6	2670	3000	3300	2750	3100	3400
	A2A30M600	A2A35M600	6000	3654	3769	6767	6842	7145	7145	165	170	165	170	3/6	2350	2650	2950	2500	2800	3100
Duplex full-free mast	A2A30U250	A2A35U250	2500	1834	1934	3316	3391	3645	3645	1018	1043	689	789	6/12	3000	3500	3800	3000	3500	3800
	A2A30U270	A2A35U270	2700	1934	2034	3516	3591	3845	3845	1118	1143	789	889	6/12	3000	3500	3800	3000	3500	3800
	A2A30U300	A2A35U300	3000	2084	2184	3816	3891	4145	4145	1268	1293	939	1039	6/12	3000	3500	3800	3000	3500	3800
	A2A30U330	A2A35U330	3300	2234	2334	4116	4191	4445	4445	1418	1443	1089	1189	6/12	3000	3500	3800	3000	3500	3800
	A2A30U360	A2A35U360	3600	2384	2484	4416	4491	4745	4745	1568	1593	1239	1339	6/12	3000	3500	3800	3000	3500	3800
	A2A30U400	A2A35U400	4000	2634	2734	4816	4891	5145	5145	1818	1843	1489	1589	6/12	3000	3500	3800	3000	3500	3800
Triplex full-free mast	A2A30N400	A2A35N400	4000	2019	2119	4816	4891	5145	5145	1203	1228	874	974	6/6	3000	3400	3700	3000	3500	3800
	A2A30N430	A2A35N430	4300	2119	2219	5116	5191	5445	5445	1303	1328	974	1074	6/6	3000	3300	3600	3000	3400	3700
	A2A30N450	A2A35N450	4500	2169	2319	5316	5391	5645	5645	1353	1428	1074	1174	6/6	3000	3200	3500	3000	3300	3600
	A2A30N470	A2A35N470	4700	2269	2419	5516	5591	5845	5845	1453	1528	1174	1274	6/6	2900	3100	3400	2950	3200	3500
	A2A30N480	A2A35N480	4800	2319	2469	5616	5691	5945	5945	1503	1578	1274	1374	6/6	2900	3100	3400	2950	3200	3500
	A2A30N500	A2A35N500	5000	2419	2619	5816	5891	6145	6145	1603	1728	1474	1474	6/6	2850	3100	3350	2900	3200	3450
	A2A30N550	A2A35N550	5500	2619	2869	6316	6391	6645	6645	1803	1978	1474	1724	3/6	2670	3000	3250	2750	3100	3350
	A2A30N600	A2A35N600	6000	2869	3119	6816	6919	7145	7145	2053	2200	1724	1974	3/6	2350	2650	2900	2500	2800	3050
	A2A30N650	A2A35N650	6500	3119	3369	7316	7391	7645	7645	2303	2478	1974	2224	3/6	2000	2250	2500	2200	2400	2650
	A2A30N700	A2A35N700	7000	3369	3619	7816	7919	8145	8145	2553	2700	2274	2474	3/6	1650	1850	2100	1850	2050	2250

SUBTRACT 100kg WITH INTEGRAL SIDESHIFTER,SUBTRACT 200kg WITH EXTERNAL SIDESHIFTER.

XE Series Electric Forklift Truck With Lithium Power (3-3.8H1)t Mast Specification

Type	Model		Lifting height	Lowered overall height		Overall height				Free lift height				Tilt range	Capacity (Mast vertical to ground)					
						Without backrest		With backrest		Without backrest		With backrest			Load Capacity at 500mm			Load Capacity at 500mm		
						3t	3.5/3.8t	3t	3.5/3.8t	3t	3.5/3.8t	3t	3.5/3.8t		FWD/RWD	Single Tire			Double tire	
Duplex wide view mast	3t	3.5/3.8t	mm	mm	mm	mm	mm	mm	mm	mm	mm	mm	mm	(°)	kg	kg	kg	kg	kg	kg
	XR30M200	XRZ35M200	2000	1554	1669	2767	2842	3145	3145	165	170	165	170	6/6	3000	3500	3800	3000	3500	3800
	XR30M250	XRZ35M250	2500	1804	1919	3267	3342	3645	3645	165	170	165	170	6/12	3000	3500	3800	3000	3500	3800
	XR30M270	XRZ35M270	2700	1904	2019	3467	3542	3845	3845	165	170	165	170	6/12	3000	3500	3800	3000	3500	3800
	XR30M300	XRZ35M300	3000	2054	2169	3767	3842	4145	4145	165	170	165	170	6/12	3000	3500	3800	3000	3500	3800
	XR30M330	XRZ35M330	3300	2204	2319	4067	4142	4445	4445	165	170	165	170	6/12	3000	3500	3800	3000	3500	3800
	XR30M360	XRZ35M360	3600	2404	2469	4367	4442	4745	4745	165	170	165	170	6/12	3000	3500	3800	3000	3500	3800
	XR30M400	XRZ35M400	4000	2654	2769	4767	4842	5145	5145	165	170	165	170	6/12	3000	3500	3800	3000	3500	3800
	XR30M430	XRZ35M430	4300	2804	2919	5067	5142	5445	5445	165	170	165	170	6/6	3000	3400	3700	3000	3500	3800
	XR30M450	XRZ35M450	4500	2904	3019	5267	5342	5645	5645	165	170	165	170	6/6	3000	3300	3600	3000	3400	3700
	XR30M480	XRZ35M480	4800	3054	3169	5567	5642	5945	5945	165	170	165	170	6/6	2950	3200	3500	3000	3300	3600
	XR30M500	XRZ35M500	5000	3154	3269	5767	5842	6145	6145	165	170	165	170	6/6	2850	3100	3400	2900	3200	3500
	XR30M550	XRZ35M550	5500	3404	3519	6267	6342	6645	6645	165	170	165	170	3/6	2670	3000	3300	2750	3100	3400
	XR30M600	XRZ35M600	6000	3654	3769	6767	6842	7145	7145	165	170	165	170	3/6	2350	2650	2950	2500	2800	3100
Duplex full-free mast	XR30U250	XRZ35U250	2500	1834	1934	3316	3391	3645	3645	1018	1043	689	789	6/12	3000	3500	3800	3000	3500	3800
	XR30U270	XRZ35U270	2700	1934	2034	3516	3591	3845	3845											

XE Series Electric Forklift Truck With Lithium Power Specification

Distinguishing mark	HANGCHA GROUP CO.,LTD.							
	1.1	1.2	1.3	1.4	1.5	1.6	1.8	1.9
1.1	Manufacturer							
1.2	Manufacturers type designation	CPD30-XEY2-SI	CPD35-XEY2-SI	CPD38-XEY2-SI	CPD30-XEY2H1-SI*	CPD35-XEY2H1-SI*	CPD38-XEY2H1-SI*	
1.3	Drive: electric (battery or mains), diesel, petrol, fuel gas	Electric	Electric	Electric	Electric	Electric	Electric	Electric
1.4	Operator type: hand, pedestrian, standing, seated, order-picker	Seated	Seated	Seated	Seated	Seated	Seated	Seated
1.5	Load capacity/rated load	Q (kg)	3000	3500	3800	3000	3500	3800
1.6	Load centre distance	c (mm)	500	500	500	500	500	500
1.8	Load distance, centre of drive axle to fork	x (mm)	477.5	482.5	482.5	477.5	482.5	482.5
1.9	Wheelbase	y (mm)	1750	1750	1750	1750	1750	1750
2.1	Service Weight	kg	4250	4630	4860	4440	4820	5050
2.2	Axle loading, laden front/rear	kg	6350/900	7170/960	7650/1010	6480/960	7300/1020	7780/1070
2.3	Axle loading, unladen front/rear	kg	1730/2520	1760/2870	1780/3080	1775/2665	1815/3005	1830/3220
3.1	Tyres: solid rubber, super elastic, pneumatic, polyurethane		Pneumatic	Pneumatic	Pneumatic	Pneumatic	Pneumatic	Pneumatic
3.2	Tyre size, front		28x9-15-14PR	28x9-15-14PR	28x9-15-14PR	28x9-15-14PR	28x9-15-14PR	28x9-15-14PR
3.3	Tyre size, rear		6.50-10-10PR	6.50-10-10PR	6.50-10-10PR	6.50-10-10PR	6.50-10-10PR	6.50-10-10PR
3.5	Wheels, number front rear (x = driven wheels)		2x/2	2x/2	2x/2	2x/2	2x/2	2x/2
3.6	Tread, front	b10 (mm)	1005	1005	1005	1005	1005	1005
3.7	Tread, rear	b11 (mm)	975	975	975	975	975	975
4.1	Tilt of mast/fork carriage forward/backward	$\alpha/\beta(^{\circ})$	6/12	6/12	6/12	6/12	6/12	6/12
4.2	Height, mast lowered	h1 (mm)	2054	2169	2169	2054	2169	2169
4.3	Free lift	h2 (mm)	165	170	170	165	170	170
4.4	Lift	h3 (mm)	3000	3000	3000	3000	3000	3000
4.5	Height, mast extended	h4 (mm)	4145	4145	4145	4145	4145	4145
4.7	Height of overhead guard STD.	h6 (mm)	2180	2180	2180	2180	2180	2180
4.8	Seat height/stand height	h7 (mm)	1126	1126	1126	1144	1144	1144
4.12	Coupling height	h10 (mm)	515	515	515	515	515	515
4.19	Overall length	l1 (mm)	3735	3740	3740	3735	3740	3740
4.20	Length to face of forks	l2 (mm)	2665	2670	2670	2665	2670	2670
4.21	Overall width	b1 (mm)	1225	1225	1225	1225	1225	1225
4.22	Fork dimensions	s/e/l (mm)	45x122x1070	50x122x1070	50x122x1070	45x122x1070	50x122x1070	50x122x1070
4.23	Fork carriage DIN 15 173 --- ISO 2328, class/type A,B		ISO2328 3A	ISO2328 3A	ISO2328 3A	ISO2328 3A	ISO2328 3A	ISO2328 3A
4.24	Fork-carriage width	b3 (mm)	1100	1100	1100	1100	1100	1100
4.25	Distance between fork-arms	b5 (mm)	290/1100	290/1100	290/1100	290/1100	290/1100	290/1100
4.31	Ground clearance, laden, below mast	m1 (mm)	139	139	139	139	139	139
4.32	Ground clearance, centre of wheelbase	m2 (mm)	155	155	155	155	155	155
4.34.1	Aisle width for pallets 1000 x 1200 crossways	Ast (mm)	4027.5	4032.5	4032.5	4097.5	4102.5	4102.5
4.34.2	Aisle width for pallets 800 x 1200 Lengthways	Ast (mm)	4227.5	4232.5	4232.5	4297.5	4302.5	4302.5
4.35	Turning radius	Wa (mm)	2350	2350	2350	2420	2420	2420
4.36	Internal turning radius	b13 (mm)	/	/	/	/	/	/
5.1	Travel speed, laden/unladen	km/h	14/15	14/15	14/15	17/18	17/18	17/18
5.2	Lift speed, laden/unladen	mm/s	290/400	290/350	290/350	400/500	350/440	350/440
5.3	Lowering speed, laden/unladen	mm/s	440/370	440/370	440/370	500/390	500/390	500/390
5.5	Drawbar pull, laden/unladen	N	/	/	/	/	/	/
5.6	Max. Drawbar pull, laden/unladen	N	11000	11000	11000	13000	13000	13000
5.7	Gradeability, laden/unladen	%	/	/	/	/	/	/
5.8	Max. gradeability, laden/unladen	%	18/25	16/25	15/25	20/25	18/25	17/25
5.9	Acceleration time, laden/unladen (0-10m)	s	/	/	/	/	/	/
5.10	Service brake		Hydraulic	Hydraulic	Hydraulic	Hydraulic	Hydraulic	Hydraulic
5.11	Parking brake		Mechanical	Mechanical	Mechanical	Mechanical	Mechanical	Mechanical
6.1	Drive motor rating S2 60 min	kW	15AC	15AC	15AC	16AC	16AC	16AC
6.2	Lift motor rating at S3 15%	kW	16AC	16AC	16AC	24AC	24AC	24AC
6.3	Battery voltage, Std.	V/Ah	80/230	80/230	80/230	80/460	80/460	80/460
	Battery voltage, Opt.	V/Ah	/	/	/	/	/	/
6.5	Min. battery weight	kg	200	200	200	320	320	320
	Max. battery weight	kg	/	/	/	/	/	/
8.1	Type of drive control		MOSFET/AC	MOSFET/AC	MOSFET/AC	MOSFET/AC	MOSFET/AC	MOSFET/AC
9.1	Manufacturer		Enpower	Enpower	Enpower	Enpower	Enpower	Enpower
6.9	Type		MC3808	MC3808	MC3808	MC3808	MC3808	MC3808
10.1	Operating pressure for attachments	bar	185	185	185	185	185	185
10.2	Oil volume for attachments	l/min	/	/	/	/	/	/
10.3	Hydraulic Tank - capacity (drain & refill)	liter	34	34	34	34	34	34
10.7	Sound level at the driver's ear according to EN / DIN 12 053	dB (A)	86	86	86	86	86	86
10.8	Towing coupling, type DIN		ϕ 25 Pin	ϕ 25 Pin	ϕ 25 Pin	ϕ 25 Pin	ϕ 25 Pin	ϕ 25 Pin

*heavy-duty model

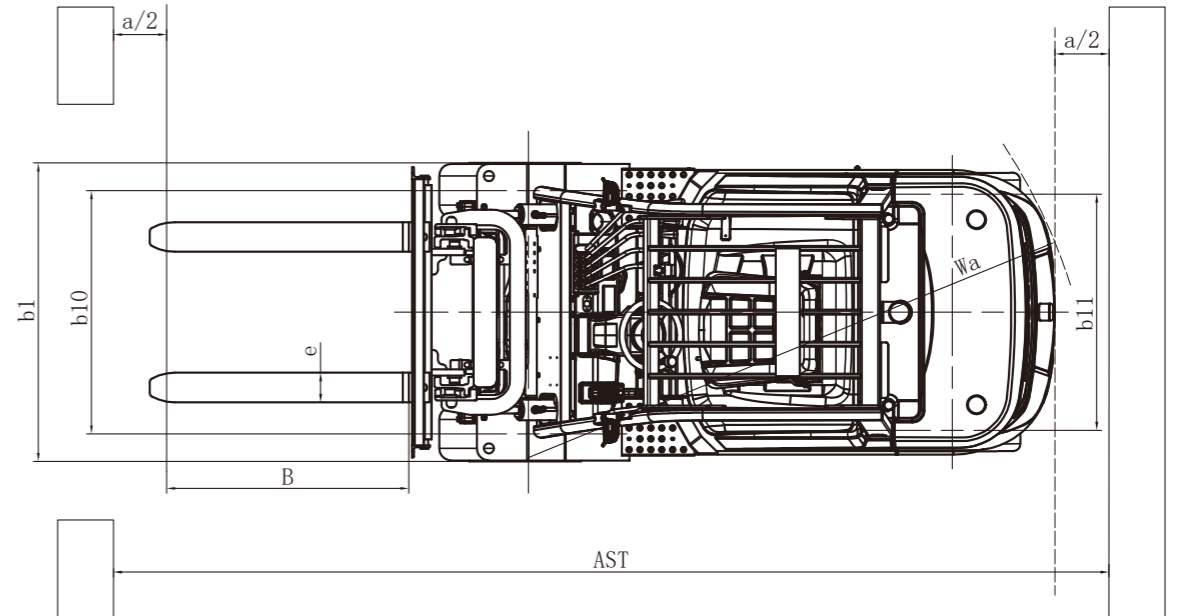
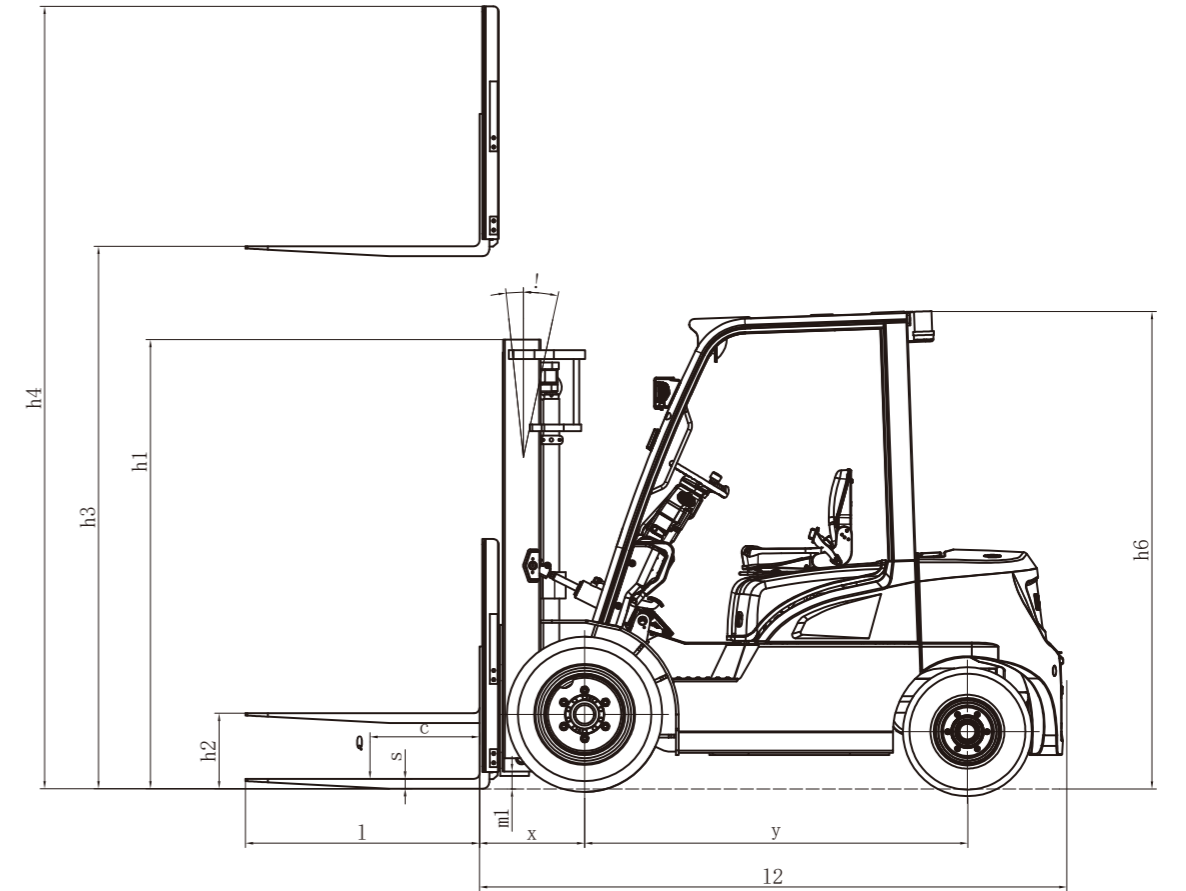

$$AST = a + Wa + x + B \quad a: \text{Clearance (200mm)}$$

