



ZHEJIANG HANGCHA IMP. & EXP. CO., LTD.

Factory site: No. 88, Donghuan Rd., Lin'an Economic Development Zone, Zhejiang, China (311305)

Tel: +86-571-88926735 88926755
Fax: +86-571-88132890 88926789

sales@hcforklift.com
www.hcforklift.com



2017 VERSION 4/COPYRIGHT 2017/006



ISO 14001
ISO 14001:2004



ISO 9001
ISO 9001:2008



HANGCHA trucks conform to the European Safety Requirements.

HANGCHA GROUP CO., LTD. reserves the right to make any changes without notice concerning colors, equipment, or specifications detailed in this brochure, or to discontinue individual models. The colors of trucks, delivered may differ slightly from those in brochures.



A Series Electric Forklift Truck

with capacities of 4,000 to 4,990kg

The World of Hangcha





High Performance

- / Electromagnetic brake is used as service brake, instead of traditional hand brake, which realizes intelligent parking brake, with lower labor intensity of the operator, and higher safety.
- / Soft landing system lowers descending speed automatically when fork reaches the height range of 100-60mm from the ground, so as to reduce vibration of the entire truck, and provide effective protection for goods.
- / Full AC configuration includes AC traction motor + AC pump motor; With higher performance of entire truck, and longer battery life.
- / Efficient driving control system of high-frequency MOSFET integrated controller guarantees smooth and accurate control on driving and lifting, superior speed regulation performance, with regenerative braking, reverse braking, anti-slipping on slope and other functions, resulting in more efficient, safer, and more comfortable operations.
- / The application of load sensing hydraulic power steering technology realizes reliable, sensitive, and easy steering; distribution of optimized oil in steering oil circuit and working oil circuit increases efficiency of hydraulic system.
- / LED lights for entire truck reduce energy consumption.

Appearance

- / It follows the entire profile of appearance of A series, with clear lines on side of the truck, and smooth transition to counter weight. These lines are shaped as an integral whole, with powerful visual tension.

Maintenance

- / Fully-openable cover enables easy maintenance of battery.
- / Easy-to-open airtight cover plate realizes easier debugging and maintenance of electric control system, and avoids the system from invasion of rain and dust.
- / The brushless, maintenance-free AC drive motor reduces operation cost significantly.
- / The option of side roll out battery is very convenient for fast, efficient, and safe replacement of battery, and is suitable for continuous work conditions.



Comfort

- / The adjustable, small-diameter steering wheel with tilt designed based on ergonomics offers good hand feeling, and the seat can also be adjusted forward and backward, which can provide best driving position for the operator.
- / Head-up display are applied to increase visibility, operability of meters, thus with higher driving safety.
- / Silent running of entire truck, with extremely small vibration, offers more comfortable acoustical environment for the operator.
- / Integrated control valve makes levers be placed at the most comfortable position for hands, resulting in lower labor intensity of the operator.

Stability

- / The internationally advanced parallel arrangement is adopted for traction motor, and the battery is sunken to chassis, resulting in lower gravity center and better stability of entire truck.
- / Flexible steering system, with smaller turning radius, allows stable turnaround within confined passageway.

Reliability & Safety

- / Major electrical components such as motor controller, contactor, power plug, and emergency power off switch are all of foreign famous brands.
- / Major load bearing parts such as carriage, drive axle, steering axle, and mast are all designed with high strength to satisfy high-strength work conditions.
- / As a standard configuration, the emergency power off switch complies with European safety standards.
- / Dual overload protection systems of electronic and hydraulic modes are adopted.



Ergonomic design



Easy to see display



Easy for maintenance



Smaller turning radius

Simple/
Solid/
Smart



Standard Specification

- / High efficiency AC driving motor
- / Multi-functions instrument
- / Rubber floor mat
- / PC Platfond
- / Emergency disconnect switch
- / Pneumatic tyre
- / Electronic parking brake
- / Battery slung removing
- / 2-way-valve
- / LED combination headlight
- / LED rear combination light
- / Panoramic rearview mirror (in the middle position of the overhead guard)
- / 3 meters duplex mast
- / Adjustable steering column
- / Full electronic controlled traveling, lifting and steering
- / Horn and reversing buzzer
- / Toolbox and file folder
- / CAN-BUS system
- / Low noise gear pump (Brand: Shimadzu, Made in Japan)
- / Full hydraulic power steering
- / Soft landing system
- / OPS system

Options

- / Solid tyre
- / Non-marking tyre
- / 3rd or 4th hydraulic function
- / 2.5-5 meters duplex mast
- / 4.0-6 meters triplex mast
- / Rear working LED light
- / Reversing assist grip with horn button
- / Integrated side shift
- / Other attachments
- / Other dimension forks
- / Special carriage and backrest
- / Big capacity battery
- / Battery side roll-out
- / Fingertip control on the adjustable armrest
- / Suspension seat
- / Cold store protection
- / Full closed cabin
- / Blue spot light
- / Alarm lamp
- / Lateral rearview mirror

4.0t A Series Mast Specification

Type	Max. fork height	Lowered	Overall height		Free lift		Tilting range		Capacity	
			With backrest	Without backrest	With backrest	Without backrest	F	R	Load capacity at 500mm	
			mm	mm	mm	mm	(°)	(°)	Single tire	Double tire
STD Duplex	2500	1955	3670	3330	150	150	6	11	4000	4000
	2700	2095	3870	3530	150	150	6	11	4000	4000
	3000	2245	4170	3830	150	150	6	11	4000	4000
	3300	2395	4470	4130	150	150	6	11	4000	4000
	3500	2495	4670	4330	150	150	6	11	4000	4000
	3600	2545	4770	4430	150	150	6	11	4000	4000
	4000	2975	5170	4830	150	150	6	11	3800	4000
	4300	2960	5470	5130	150	150	6	6	3600	3800
	4500	3070	5670	5330	150	150	6	6	3400	3600
	4800	3235	5970	5630	150	150	6	6	3000	3200
5000	3345	6170	5830	150	150	6	6	2800	3000	
Full Free Lift	2500	1976	3670	3365	809	1115	6	11	4000	4000
	2750	2100	3920	3615	933	1238	6	11	4000	4000
	3000	2226	4170	3865	1055	1365	6	11	4000	4000
	3300	2376	4470	4165	1205	1515	6	11	4000	4000
Triplex	4000	2080	5170	4850	912	1229	6	11	4000	4000
	4300	2180	5470	5150	1012	1329	6	6	3400	3600
	4500	2248	5670	5365	1080	1395	6	6	3200	3400
	4800	2340	5970	5650	1172	1489	6	6	3000	3200
	5000	2410	6170	5855	1242	1559	6	6	2600	3000
	5500	2575	6670	6355	1408	1724	3	6	2250	2800
6000	2790	7170	6865	1622	1939	3	6	1700	2600	

4.5t A Series Mast Specification

Type	Max. fork height	Lowered	Overall height		Free lift		Tilting range		Capacity	
			With backrest	Without backrest	With backrest	Without backrest	F	R	Load capacity at 500mm	
			mm	mm	mm	mm	(°)	(°)	Single tire	Double tire
STD Duplex	2500	1955	3670	3330	150	150	6	11	4500	4500
	2700	2095	3870	3530	150	150	6	11	4500	4500
	3000	2245	4170	3830	150	150	6	11	4500	4500
	3300	2395	4470	4130	150	150	6	11	4500	4500
	3500	2495	4670	4330	150	150	6	11	4500	4500
	3600	2545	4770	4430	150	150	6	11	4500	4500
	4000	2975	5170	4830	150	150	6	11	4250	4500
	4300	2960	5470	5130	150	150	6	6	4000	4250
	4500	3070	5670	5330	150	150	6	6	3800	4050
	4800	3235	5970	5630	150	150	6	6	3350	3600
5000	3345	6170	5830	150	150	6	6	3150	3400	
Full Free Lift	2500	1976	3670	3365	809	1115	6	11	4500	4500
	2750	2100	3920	3615	933	1238	6	11	4500	4500
	3000	2226	4170	3865	1055	1365	6	11	4500	4500
	3300	2376	4470	4165	1205	1515	6	11	4500	4500
Triplex	4000	2080	5170	4850	912	1229	6	11	4500	4500
	4300	2180	5470	5150	1012	1329	6	6	3800	4050
	4500	2248	5670	5365	1080	1395	6	6	3600	3850
	4800	2340	5970	5650	1172	1489	6	6	3350	3600
	5000	2410	6170	5855	1242	1559	6	6	3150	3400
	5500	2575	6670	6355	1408	1724	3	6	2550	3100
6000	2790	7170	6865	1622	1939	3	6	1950	2800	

4.99t A Series Mast Specification

Type	Max. fork height	Lowered	Overall height		Free lift		Tilting range		Capacity	
			With backrest	Without backrest	With backrest	Without backrest	F	R	Load capacity at 500mm	
			mm	mm	mm	mm	(°)	(°)	Single tire	Double tire
STD Duplex	2500	1955	3865	3330	150	150	6	11	4990	4990
	2700	2095	4065	3530	150	150	6	11	4990	4990
	3000	2245	4365	3830	150	150	6	11	4990	4990
	3300	2395	4665	4130	150	150	6	11	4990	4990
	3500	2495	4865	4330	150	150	6	11	4990	4990
	3600	2545	4965	4430	150	150	6	11	4990	4990
	4000	2975	5365	4830	150	150	6	11	4750	4990
	4300	2960	5665	5130	150	150	6	6	4500	4750
	4500	3070	5865	5330	150	150	6	6	4250	4500
	4800	3235	6165	5630	150	150	6	6	3750	4000
5000	3345	6365	5830	150	150	6	6	3500	3750	
Full Free Lift	2500	1976	3670	3305	610	1115	6	11	4990	4990
	2750	2100	3920	3555	735	1238	6	11	4990	4990
	3000	2226	4170	3805	860	1365	6	11	4990	4990
	3300	2376	4470	4105	1010	1515	6	11	4990	4990
Triplex	4000	2080	5170	4860	715	1222	6	11	4750	4990
	4300	2180	5470	5160	815	1322	6	6	4200	4500
	4500	2248	5670	5370	883	1390	6	6	4000	4250
	4800	2340	5970	5660	975	1482	6	6	3750	4000
	5000	2410	6170	5860	1045	1552	6	6	3500	3750
	5500	2575	6670	6360	1210	1718	3	6	2850	3350
6000	2790	7170	6870	1425	1932	3	6	2200	2950	

A Series Electric Forklift Truck

Distinguishing mark	HANGCHA GROUP CO.,LTD.								
	1.1	Manufacturer		CPD40-AC4	CPD40-AZ4	CPD45-AC4	CPD45-AZ4	CPD50-AC4	CPD50-AZ4
1.2	Manufacturers type designation		CPD40-AC4	CPD40-AZ4	CPD45-AC4	CPD45-AZ4	CPD50-AC4	CPD50-AZ4	
1.3	Drive: electric (battery or mains), diesel, petrol, fuel gas		electric	electric	electric	electric	electric	electric	
1.4	Operator type: hand, pedestrian, standing, seated, order-picker		seated	seated	seated	seated	seated	seated	
1.5	Load capacity/rated load	Q (kg)	4000	4000	4500	4500	4990	4990	
1.6	Load centre distance	c (mm)	500	500	500	500	500	500	
1.8	Load distance, centre of drive axle to fork	x (mm)	550	550	550	550	550	550	
1.9	Wheelbase	y (mm)	1970	1970	1970	1970	1970	1970	
Weight	2.1	Service Weight	kg	6700	6700	6950	6950	7220	7220
	2.2	Axle loading, laden front/rear	kg	9530/1170	9530/1170	10250/1200	10250/1200	10980/1240	10980/1240
2.3	Axle loading, unladen front/rear	kg	3290/3410	3290/3410	3330/3620	3330/3620	3335/3885	3335/3885	
Tyres, chassis	3.1	Tyres: solid rubber, superelastic, pneumatic, polyurethane		pneumatic	pneumatic	pneumatic	pneumatic	pneumatic	pneumatic
	3.2	Tyre size, front		250 - 15	250 - 15	250 - 15	250 - 15	28x12.5 - 15	28x12.5 - 15
	3.3	Tyre size, rear		23x10 - 12	23x10 - 12	23x10 - 12	23x10 - 12	23x10 - 12	23x10 - 12
	3.5	Wheels, number front rear (x = driven wheels)		2x/2	2x/2	2x/2	2x/2	2x/2	2x/2
	3.6	Tread, front	b10 (mm)	1150	1150	1150	1150	1150	1150
	3.7	Tread, rear	b11 (mm)	1175	1175	1175	1175	1175	1175
	4.1	Tilt of mast/fork carriage forward/backward	$\alpha/\beta(^{\circ})$	6/11	6/11	6/11	6/11	6/11	6/11
Dimensions	4.2	Height, mast lowered	h1 (mm)	2185	2185	2185	2185	2185	2185
	4.3	Free lift	h2 (mm)	150	150	150	150	150	150
	4.4	Lift	h3 (mm)	3000	3000	3000	3000	3000	3000
	4.5	Height, mast extended	h4 (mm)	4170	4170	4170	4170	4170	4170
	4.7	Height of overhead guard STD.	h6 (mm)	2310	2310	2310	2310	2310	2310
	4.9	Seat height/stand height	h7 (mm)	1240	1240	1240	1240	1240	1240
	4.12	Coupling height	h10 (mm)	350	350	350	350	350	350
	4.19	Overall length	l1 (mm)	3997	3997	3997	3997	4037	4037
	4.20	Length to face of forks	l2 (mm)	2927	2927	2927	2927	2967	2967
	4.21	Overall width	b1 (mm)	1440	1440	1440	1440	1470	1470
	4.22	Fork dimensions	s/e/l (mm)	50/122/1070	50/122/1070	50/150/1070	50/150/1070	55/150/1070	55/150/1070
	4.23	Fork carriage DIN 15 173 --- ISO 2328, class/type A,B		ISO2328 3A	ISO2328 3A	ISO2328 3A	ISO2328 3A	ISO2328 3A	ISO2328 3A
	4.24	Fork-carriage width	b3 (mm)	1250	1250	1250	1250	1250	1250
	4.25	Distance between fork-arms	b5 (mm)	310/1250	310/1250	310/1250	310/1250	310/1250	310/1250
	4.31	Ground clearance, laden, below mast	m1 (mm)	110	110	110	110	110	110
	4.32	Ground clearance, centre of wheelbase	m2 (mm)	150	150	150	150	150	150
	4.34.1	Aisle width for pallets 1000 x 1200 crossways	Ast (mm)	4390	4390	4390	4390	4425	4425
	4.34.2	Aisle width for pallets 800 x 1200 lengthways	Ast (mm)	4590	4590	4590	4590	4625	4625
	4.35	Turning radius	Wa (mm)	2640	2640	2640	2640	2675	2675
	4.36	Internal turning radius	b13 (mm)	810	810	810	810	810	810
Performance Data	5.1	Travel speed, laden/unladen	km/h	14/14	14/14	13.5/14	13.5/14	13/13.5	13/13.5
	5.2	Lift speed, laden/unladen	m/s	0.270/0.430	0.270/0.430	0.260/0.420	0.260/0.420	0.250/0.400	0.250/0.400
	5.3	Lowering speed, laden/unladen	m/s	0.430/0.480	0.430/0.480	0.440/0.480	0.440/0.480	0.440/0.480	0.440/0.480
	5.5	Drawbar pull, laden/unladen	N	16400 /17000	16400 /17000	15600 /16200	15600 /16200	15200/15600	15200/15600
	5.6	Max. Drawbar pull, laden/unladen	N	24000	24000	26000	26000	27000	27000
	5.7	Gradeability, laden/unladen	%	14.5/15.5	14.5/15.5	14/15	14/15	13/14	13/14
	5.8	Max. gradeability, laden/unladen	%	16/28	16/28	15/27	15/27	14/25	14/25
	5.9	Acceleration time, laden/unladen (0-10m)	s	5.2/5.4	5.2/5.4	5.3/5.5	5.3/5.5	5.4/5.6	5.4/5.6
	5.10	Service brake		Hydraulic	Hydraulic	Hydraulic	Hydraulic	Hydraulic	Hydraulic
	5.11	Parking brake		electric	electric	electric	electric	electric	electric
	Electric engine	6.1	Drive motor rating S2 60 min	kW	16.6 AC	16.6 AC	16.6 AC	16.6 AC	16.6 AC
6.2		Lift motor rating at S3 15%	kW	25.4 AC	25.4 AC	25.4 AC	25.4 AC	25.4 AC	25.4 AC
6.3		Battery acc. to DIN 43 531/35/36 A,B,C, no		DIN 43536A	DIN 43536A	DIN 43536A	DIN 43536A	DIN 43536A	DIN 43536A
6.4		Battery voltage, nominal capacity K5	V/Ah	80/700	80/700	80/700	80/700	80/700	80/700
6.5		Battery weight	kg	1863	1863	1863	1863	1863	1863
6.5		Battery dimensions	l/b/h(mm)	1028*855*784	1028*855*784	1028*855*784	1028*855*784	1028*855*784	1028*855*784
6.6		Energy consumption acc. to VDI cycle	kWh/h	12.5	12.5	13	13	13.5	13.5
Addition data	8.1	Type of drive control		MOSFET/AC	MOSFET/AC	MOSFET/AC	MOSFET/AC	MOSFET/AC	MOSFET/AC
	9.1	Manufacturer		CURTIS	ZAPI	CURTIS	ZAPI	CURTIS	ZAPI
	10.1	Operating pressure for attachments	bar	185	185	185	185	185	185
	10.2	Oil volume for attachments	l/min	65	65	65	65	65	65
	10.3	Hydraulic Tank - capacity (drain & refill)	liter	46	46	46	46	46	46
	10.7	Sound level at the driver's ear according to EN / DIN 12 053	dB (A)	75	75	75	75	76	76
	10.8	Towing coupling, type DIN		Φ24 Pin	Φ24 Pin	Φ24 Pin	Φ24 Pin	Φ24 Pin	Φ24 Pin

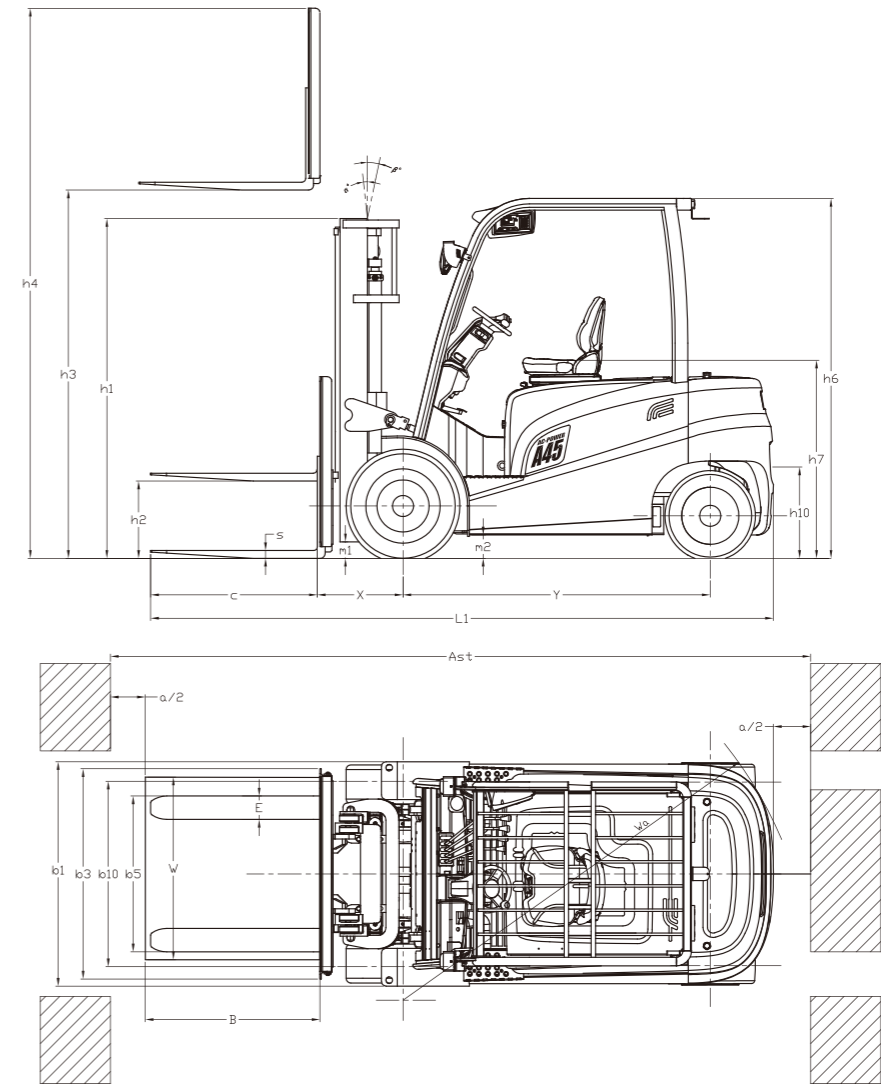

a=200 mm safety clearance
AST=a+Wa+ X+B

LOAD CHART

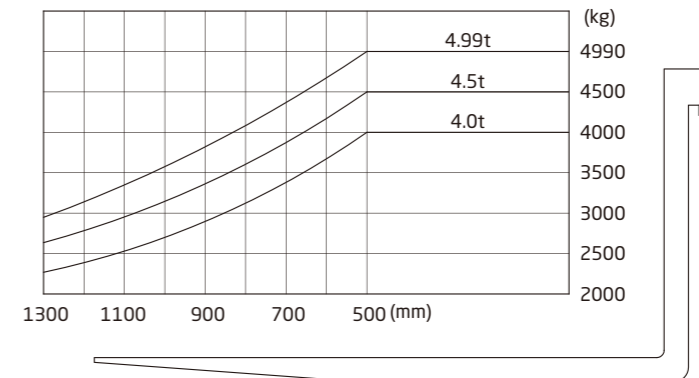

AC4: meansCURTIS AC traveling system with AC Pump system, full-AC system
AZ4: meansZAPI AC traveling system with AC Pump system, full-AC system